



Commercial Energy Saver Gas Millivolt Models

Standard Equipment Features:

 Bradford White is ISO registered to the 9001-standard.

- Non-CFC foam insulation.
- Vitraglas® lined tank.
- Factory installed Hydrojet® Sediment Reduction System.
- Factory installed dielectric fittings.
- Flue damper.
- Continuous pilot-ignition.
- Magnesium anode rods.
- Hand hole cleanout.
- Millivolt controls.
- Brass drain valve.
- T&P relief valve installed.
- Millivolt models are available from 125,000 to 270,000 BTUH (36.6 KW to 79.1 KW)
- Three year limited warranty.
- One year limited parts warranty.
- Design certified by CSA International (formerly AGA and CGA)
- All models listed with California Energy Commission.

Optional Features:

- NSF construction available.
- ASME code available on all models above 200,000 BTUH (58.6KW)

MANUFACTURED UNDER ONE OR MORE OF THE FOLLOWING U.S. PATENTS:
5,954,492; 5,761,379; 5,943,984; 5,081,696; 5,988,117; 6,142,216; 5,199,385;
6,684,821; 5,574,822; 5,372,185; 5,485,879; 5,277,171; (B1)5,341,770; 5,660,165;
5,596,952; 5,682,666; 4,904,428; 5,023,031; 5,000,893; 4,669,448; 4,829,983;
4,808,356; 5,115,767; 5,092,519; 5,052,346; 4,416,222; 4,628,184; 4,861,968;
4,672,919; Re. 34,534. OTHER U.S. AND FOREIGN PATENT APPLICATIONS
PENDING. CURRENT CANADIAN PATENTS: 1,272,914; 1,280,043; 1,289,832;
2,045,862; 2,112,515; 2,108,186; 2,107,012, 2,092,105.



Standard Equipment Features:

Non-CFC foam insulation.

Vitraglas® lined tank—Bradford White water heater tanks are protected from the corrosive effects of hot water by an exclusive ceramic porcelain-like coating. The Bradford White high silica Vitraglas® lining provides a tough interior surface for our water heater tanks, which must withstand the wearing effects of high volume and high temperature hot water.

Factory installed Hydrojet® Sediment Reduction System—cold inlet sediment reduction device. Helps prevent sediment build up in tank.

Factory installed dielectric fittings—all heaters equipped with special water heater nipples for longer heater life. No special dielectric fittings to buy.

Flue damper—automatic flue damper reduces stand-by loss, saving money and fuel.

Continuous pilot ignition—continuous pilot ignition eliminates the need for an external electric source which is used on other commercial water heaters.

Magnesium anode rods—employed to provide an extra measure of corrosion prevention for longer life.

Hand hole cleanout—allows inspection of tank interior and facilitates removal of water heater's principal deterrent to long life—accumulated lime and sediment deposits.

Millivolt controls—no external electric source is required for water heater operation. Adjustable thermostat to any temperature up to 180°F (82°C). A manual reset Energy Cut-Off (E.C.O.) shuts off all gas in event of an overheat condition.

Brass drain valve.

T&P relief valve installed.

Three year limited warranty—protects your investment in a quality glass lined water heater. If the tank leaks for reasons of faulty materials, workmanship, or corrosion within the warranty period, the water heater will be replaced with a comparable water heater of our manufacture. (Exclusive of all shipping and reinstallation costs.) Some states do not allow limitations on warranties. See complete copy of the warranty included with the water heater.

One year limited parts warranty—these quality components are manufactured for us by industry leaders and will be replaced in the event of failure during the parts warranty period (exclusive of shipping and reinstallation costs.)

Design certified by CSA International (formerly AGA and CGA)

All models listed with California Energy Commission.

Optional Features:

NSF construction available.

ASME code available on all models above 200,000 BTUH (58.6KW)

Dimensions

Millivolt Models

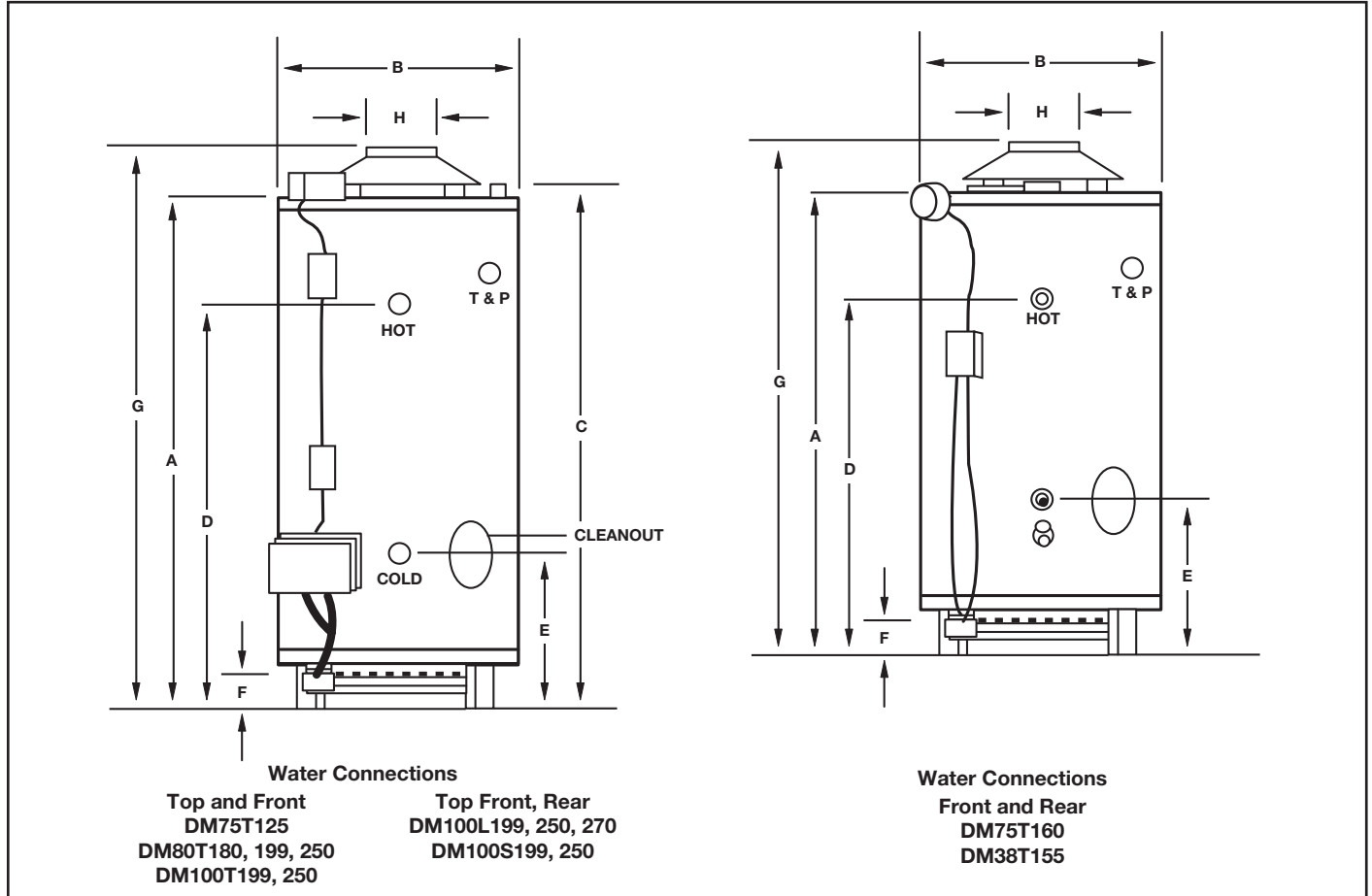

Sample Specification

The water heater shall be a Bradford White model with a storage capacity of not less than _____ gallons (_____ liters), a minimum gas input of _____ BTUH (KWH), and a minimum recovery of _____ GPH (LPH) at 100°F (56°C). temperature rise. It shall be design certified by CSA International (formerly AGA and CGA) for 180°F (82°C). application, either with or without a separate storage tank. The tank shall be lined with Vitraglas® vitreous enamel and shall have a bolted hand hole cleanout. The tank shall have _____ extruded magnesium anode rods installed in separate head couplings and extended to within three inches of the bottom. The heater shall be insulated with non-CFC foam insulation. This water heater shall be equipped with an ASME rated T&P relief valve, a continuous pilot ignition system and flue damper. The entire installation shall be made in compliance with state and local codes and ordinances.

Dimensions and specifications subject to change without notice in accordance with our policy of continuous product improvement.

MILLIVOLT MODELS Includes installed T&P Valve and Flue Damper with Continuous Pilot Ignition.

▲	MODEL NUMBER	NAT & LP INPUT BTU	1ST HR. DEL. GAL. AT 100°F RISE	RECOVERY GPH AT DEGREE RISE			STG. CAP. U.S. GAL.	DIMENSIONS IN INCHES											WEIGHT	
				40°	100°	140°		A HT.	B DIA.	C TOP WTR. CONN.	D† F&R HW CONN.	E‡ F&R CW CONN.	F GAS CONN.	G TOP VENT HT.	H VENT DIA.	WTR. CONN. DIA.	GAS CONN. DIA.	RELIEF VALVE OPEN.	STD.	ASME
▲	DM-38T-155-3N	155,000	174	368	147	105	38	43	28½	—	34¾	19¾	4¾	51	6	1½	¾	¾	438	—
▲	DM-75T-125-3N	125,000	174	303	121	86	75	65	28½	67¾	54¾	34	4¾	72¾	5	1½	¾	¾	520	—
▲	DM-75T-160-3N(LP)	160,000	204	378	151	108	75	65	28½	67¾	54¾	34	4¾	72¾	6	1½	¾	¾	520	—
▲	DM-80T-180-3N	180,000	231	436	175	124	80	64½	28½	66¾	56	19¾	4¾	72¾	6	1½	¾	¾	540	—
▲	DM-80T-199-3N(LP)	199,999	250	485	194	139	80	64½	28½	66¾	56	19¾	4¾	72¾	6	1½	¾	¾	540	—
▲	DM-80T-250-3N(A)(LP)	250,000	298	606	242	173	80	64½	28½	66¾	56	19¾	4¾	72¾	6	1½	¾	1	540	590
▲	DM-100T-199-3N	199,999	263	485	194	139	98	75½	28½	77¾	67	19¾	4¾	83¾	6	1½	¾	¾	610	—
▲	DM-100T-250-3N(A)(LP)	250,000	311	606	242	173	98	75½	28½	77¾	67	19¾	4¾	83¾	6	1½	¾	1	610	690
▲	DM-100L-199-3N	199,999	264	485	194	139	100	65	30¾	67	56½	23½	4½	75	6	1½ (T&F) 2(R)	¾	¾	725	—
▲	DM-100L-250-3N(A)	250,000	312	606	242	173	100	65	30¾	67	56½	23½	4½	75	6	1½ (T&F) 2(R)	¾	1	725	765
▲	DM-100L-270-3N(A)*	270,000	332	655	262	187	100	65	30¾	67	56½	23½	4½	75	6	1½ (T&F) 2(R)	¾	1	725	765
▲	DM-100S-199-3N	199,999	264	485	194	139	100	72¾	28½	75	60½	20¾	4½	76¾	6	1½ (T&F) 2(R)	¾	¾	667	—
▲	DM-100S-250-3N(A)	250,000	312	606	242	173	100	72¾	28½	75	60½	20¾	4½	76¾	6	1½ (T&F) 2(R)	¾	1	667	702

▲	MODEL NUMBER	KW INPUT	1ST HR. DEL. LTR. AT 56°C RISE	RECOVERY LPH AT DEGREE RISE			STG. LITERS	DIMENSIONS IN MILLIMETERS											WEIGHT	
				22°	56°	78°		A HT.	B DIA.	C TOP WTR. CONN.	D† F&R HW CONN.	E‡ F&R CW CONN.	F GAS CONN.	G TOP VENT HT.	H VENT DIA.	WTR. CONN. DIA.	GAS CONN. DIA.	RELIEF VALVE OPEN.	STD WT. (KG)	ASME WT. (KG)
▲	DM-38T-155-3N	45.4	659	1391	556	397	144	1092	718	—	883	492	117	1295	152	38	19	19	199	—
▲	DM-75T-125-3N	36.6	659	1147	458	326	284	1651	718	1705	1384	864	121	1835	127	38	19	19	236	—
▲	DM-75T-160-3N(LP)	46.8	772	1431	572	409	284	1651	718	1705	1384	864	121	1835	152	38	19	19	236	—
▲	DM-80T-180-3N	52.7	874	1650	662	469	303	1638	718	1683	1422	495	121	1838	152	38	19	19	245	—
▲	DM-80T-199-3N(LP)	58.6	946	1836	734	526	303	1638	718	1683	1422	495	121	1838	152	38	19	19	245	—
▲	DM-80T-250-3N(A)(LP)	73.2	1128	2294	916	655	303	1638	718	1683	1422	495	121	1838	152	38	19	25	245	268
▲	DM-100T-199-3N	58.6	995	1836	734	526	371	1918	718	1962	1702	495	121	2118	152	38	19	19	277	—
▲	DM-100T-250-3N(A)(LP)	73.2	1177	2294	916	655	371	1918	718	1962	1702	495	121	2118	152	38	19	25	277	313
▲	DM-100L-199-3N	58.6	999	1836	734	526	379	1651	768	1702	1435	597	114	1905	152	38 (T&F) 51(R)	19	19	329	—
▲	DM-100L-250-3N(A)	73.2	1181	2294	916	655	379	1651	768	1702	1435	597	114	1905	152	38 (T&F) 51(R)	19	25	329	347
▲	DM-100L-270-3N(A)*	79.0	1257	2479	992	708	379	1651	768	1702	1435	597	114	1905	152	38 (T&F) 51(R)	19	25	329	347
▲	DM-100S-199-3N	58.6	999	1836	734	526	379	1851	718	1905	1537	527	114	1949	152	38 (T&F) 51(R)	19	19	302	—
▲	DM-100S-250-3N(A)	73.2	1181	2294	916	655	379	1851	718	1905	1537	527	114	1949	152	38 (T&F) 51(R)	19	25	302	318

For LP models change suffix "N" to "X"

▲ - 80% Thermal Efficient

(A) - ASME

T - Top Water Connection

F - Front Water Connection

R - Rear Water Connection

* - Available with natural gas only.

Energy Saver Series feature Hand Hole Cleanout on all models.

Recoveries and First Hour Delivery Rating are based on Thermal Efficiencies ranging up to 80%.

150 PSI Working Pressure, 300 PSI Test Pressure.

† Rear connections offered as standard on the "L" and "S" models. DM38T155 also features rear connections.

For LowNOx compliance to meet SCAQMD requirements, place an "E" following the BTU Input identifier of the model number.

Example: DM-75T-125E-3N

Efficiency in compliance with CSA International (formerly AGA/CGA) ANSI Z21.10.3 requirements. These models meet or exceed the Thermal efficiency and standby loss requirements of ASHRAE 90.1b (current edition).

*LP Propane Gas Inputs			
	1ST HR. DEL. GAL. @ 100°F RISE/ LITER @ 56°C RISE		RECOVERY @ DEGREE RISE GPH/LPH
			40°F/22°C 100°/56°C 140°/78°C
75T-160	155,000BTU/H/45.4KW	199/753	366/1385 147/556 105/397
80T-199	190,000BTU/H/55.7KW	240/908	461/1745 184/696 132/500
80T-250	235,000BTU/H/68.9KW	284/1075	570/2157 228/863 163/616
100T-250	235,000BTU/H/68.9KW	297/1124	570/2157 228/863 163/616

All models are design certified by CSA International (formerly AGA and CGA) for up to 180°F (82°C) application as an Automatic Storage Heater, and an Automatic Circulating Tank Heater.

As an Automatic Storage Heater, all models are complete self-contained water heating systems. It needs no separate storage tank, pump, wiring or elaborate piping network. When equipped with a mixing valve, it will supply 180°F (82°C) sanitizing and 140°F (60°C). general purpose hot water simultaneously. These models can be used either as a single unit or in multiples connected in parallel.

Vitraglas® and Hydrojet® are registered trademarks of Bradford White® Corporation. ©2005 Bradford White Corporation. All rights reserved.



For U.S. and Canada field service, contact your professional installer or local Bradford White sales representative.

Sales/800-523-2931
Fax/215-641-1670

Technical Support/800-334-3393
Fax/269-795-1089

Warranty/800-531-2111
Fax/269-795-1089

International:
Telephone/215-641-9400
Telefax/215-641-9750

Fax on Demand:
888-538-7833

www.bradfordwhite.com



Sales/Technical Support
866-690-0961
905-238-0100

Fax/905-238-0105

www.bradfordwhitecanada.com

Count On Bradford White
For *Everything* Hot Water