



Residential Storage Tank AST Models

Features:



Bradford White is ISO registered to the 9001- standard.

- **Fully automatic controls**—fast acting surface-mount thermostat for automatic temperature control.
- **2" Non-CFC foam insulation**—completely covers the side and top of tank, saving energy by retarding loss of heat.
- **Vitraglas® lining**—Bradford White storage tanks are protected from the corrosive effects of hot water by an exclusive ceramic porcelain-like coating. The Bradford White high silica Vitraglas® lining provides a tough interior surface for our storage tanks.
- **Protective magnesium anode rod**—provides added protection against corrosion for long trouble-free service.
- **Factory installed dielectric waterway fittings**—for longer tank life. Easier installation.
- **Factory installed Hydrojet® Total Performance System**—Helps prevent sediment build up in tank.
- **T&P relief valve opening**—all models have special tapping on top of tank.
- **Brass drain/return valve.**
- **Six year limited warranty on steel tank**—heavy gauge steel automatically formed, rolled and welded to assure a continuous seam for glass lining.
- **Six year limited warranty on parts.**
- **Thermal Feet**—Unique design provides complete tank isolation. Prevents thermal conduction through bottom of tank.

MANUFACTURED UNDER ONE OR MORE OF THE FOLLOWING U.S. PATENTS: 5,954,492; 5,761,379; 5,943,984; 5,081,696; 5,988,117; 6,142,216; 5,199,385; 6,684,821; 5,574,822; 5,372,185; 5,485,879; 5,277,171; (B1)5,341,770; 5,660,165; 5,596,952; 5,682,666; 4,904,428; 5,023,031; 5,000,893; 4,669,448; 4,829,983; 4,808,356; 5,115,767; 5,092,519; 5,052,346; 4,416,222; 4,628,184; 4,861,968; 4,672,919; Re. 34,534. OTHER U.S. AND FOREIGN PATENT APPLICATIONS PENDING. CURRENT CANADIAN PATENTS: 1,272,914; 1,280,043; 1,289,832; 2,045,862; 2,112,515; 2,108,186; 2,107,012.



AST Models

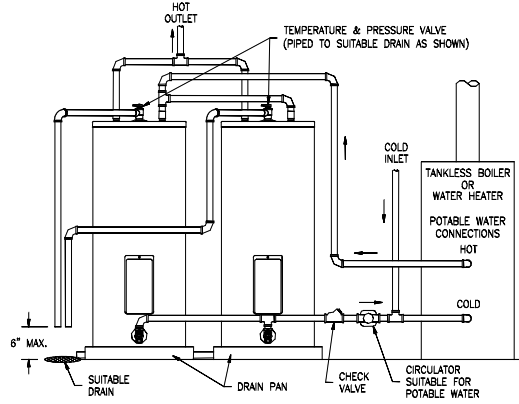
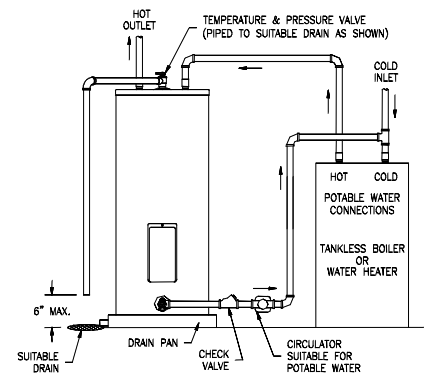
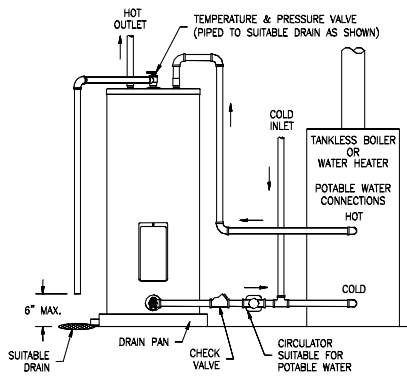
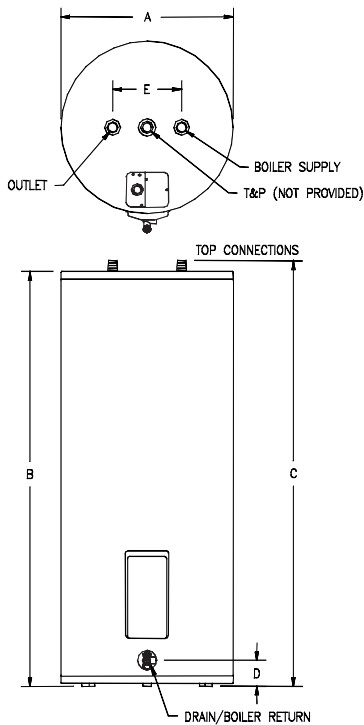

AST Models

Number	Imp. Gal.	U.S. Gal.	Liters	A		B		C		D		E		Outlet	Boiler Supply	Boiler Return	Approx. Shipping Weight	
				Jacket Diameter	Height Floor to Heater Top	Height Floor to Top Water Conn.	Height Floor to Drain/Boiler Return	Outlet to Boiler Supply	Outlet	Boiler Supply	Boiler Return	Lbs.	Kg.					
AST-40-6	33	40	151	20 in. 508 mm.	46 ¹ / ₁₆ in. 1191 mm.	47 ¹ / ₁₆ in. 1202 mm.	3 ¹ / ₁₆ in. 78 mm.	8 in. 20 mm.	3/4	3/4	3/4	103	47					
AST-50-6	42	50	189	22 in. 559 mm.	46 ¹ / ₁₆ in. 1176 mm.	47 ¹ / ₁₆ in. 1202 mm.	3 ¹ / ₁₆ in. 78 mm.	8 in. 20 mm.	3/4	3/4	3/4	130	59					
AST-80-6	67	80	303	24 in. 610 mm.	58 ¹ / ₁₆ in. 1495 mm.	59 ¹ / ₁₆ in. 1521 mm.	3 ¹ / ₁₆ in. 78 mm.	8 in. 20 mm.	3/4	3/4	3/4	183	83					
AST-120-6	99	119	450	28 ¹ / ₄ in. 718 mm.	62 ¹ / ₁₆ in. 1597 mm.	63 ¹ / ₁₆ in. 1622 mm.	3 ¹ / ₁₆ in. 78 mm.	8 in. 20 mm.	1	1	3/4	305	138					

General

Note: All Models Certified at 300 P.S.I. (2068 kPa) Test Pressure and 150 P.S.I. (1034 kPa) Working Pressure. All Water Connections 3/4" (19mm) N.P.T. (120 gallon models have 1" (25 mm) outlet, 1" (25 mm) Boiler Supply and 3/4" (19mm) Boiler return.) All models are U.L. listed.

Dimensions and specifications subject to change without notice in accordance with our policy of continuous product improvement.

6-Year Limited Warranty on Component Parts

BRADFORD WHITE CORPORATION has a 6-year warranty on replaceable parts—thermostat, dip tube, drain/return valve. These quality components are manufactured for us by industry leaders and will be replaced in the event of failure during the parts warranty period (exclusive of shipping and re-installation cost).§

6-Year Limited Tank Warranties

BRADFORD WHITE CORPORATION LIMITED WARRANTY: Protects your investment in a quality glass-lined storage tank. If the tank leaks for reasons of faulty materials, workmanship, or corrosion within the warranty period, the storage tank will be replaced with a comparable storage tank of our manufacture (exclusive of shipping and re-installation cost).§

§ Some states do not allow limitations on warranties. See complete copy of the warranty included with the product. Indicated warranties apply to USA, Canada and Puerto Rico installations.

Vitraglas® and Hydrojet® are registered trademarks of Bradford White® Corporation. ©2004, Bradford White Corporation. All rights reserved.

BRADFORD WHITE
CORPORATION
Ambler, PA

For U.S. and Canada field service, contact your professional installer or local Bradford White sales representative.

Sales/800-523-2931
Fax/215-641-1670

Technical Support/800-334-3393
Fax/269-795-1089

Warranty/800-531-2111
Fax/269-795-1089

International:
Telephone/215-641-9400
Telefax/215-641-9750

Fax on Demand:
888-538-7833

www.bradfordwhite.com

BRADFORD WHITE-CANADA™ INC.
Mississauga, ON

Sales/Technical Support
866-690-0961
905-238-0100

Fax/905-238-0105

www.bradfordwhitecanada.com