



Residential PowerStor2™ Series® Double-Wall Energy Saver Indirect Water Heater



Photo is of
DW-2-50-L

The PowerStor2™ Series® Features:

- **Heat Exchanger**—Double wall 1½" O.D. glass coated (Vitrarglas®) steel coil. The positive leak path between the two walls of the coil ensures the potable water will stay separate from the hydronic fluid.
- **Low Heat Exchanger Head Loss**—Up to 10 GPM flow, with less than 5 ft. of head loss. Greatly reduces the required pump size for heat exchange.
- **Factory installed Hydrojet® Total Performance System**—Cold water inlet sediment reducing device helps to minimize sediment build up in tank. Increases first hour delivery of hot water while minimizing temperature build up in tank.
- **Vitrarglas® Lining**—Bradford White water heater tanks are protected from the corrosive effects of hot water by an exclusive ceramic porcelain-like coating. The Bradford White high silica Vitrarglas® lining provides a tough interior surface for our hot water tanks.
- **Fully Automatic Controls**—Fast acting surface-mount thermostat for automatic temperature control.
- **Supply and Return Connections**—The 3/4" NPT female connections are located on the front for both the boiler supply and boiler return.
- **2" Non-CFC Foam Insulation**—Covers the sides and top of tank to save energy by retarding loss of heat. Also increases jacket rigidity.
- **Water Connections**—3/4" NPT factory installed true dielectric fittings extend water heater life and eases installation.
- **Two Protective Aluminum Rods**—Provide added protection against corrosion for long trouble-free service.
- **Stand-by Heat Loss**—Less than 1/2°F per hour (ASHRAE 90.1b current standard).
- **Steel Tank**—Heavy gauge steel automatically formed, rolled and welded to assure a continuous seam for glass lining.
- **T&P Relief Valve Included**—All models feature opening on side of tank.
- **Brass Drain Valve.**
- **I=B=R Certified**—These water heaters are rated by the Institute of Boiler and Radiation Manufacturers (I=B=R) to provide accurate performance data within the standards of the certification. The I=B=R rating is issued by the Hydronics Institute Division of GAMA and provides a recognized standard for proper comparison of hydronic appliances.



Limited Lifetime Tank and Heat Exchanger Warranties / 6-Year Limited Warranty on Component Parts.

For more information on warranty, please visit www.bradfordwhite.com

For products installed in USA, Canada and Puerto Rico. Some states do not allow limitations on warranties. See complete copy of the warranty included with the heater.

Bradford White received the highest numerical score among water heater/boiler manufacturers in the proprietary J.D. Power and Associates/ McGraw-Hill Construction 2006 HVAC and Water Heater/Boiler Subcontractor Satisfaction Study™. Study based on 882 responses measuring 3 water heater/boiler manufacturers and measures opinions of subcontractors. Proprietary study results are based on experiences and perceptions of subcontractors surveyed in May through July 2006. Your experiences may vary. Visit jdpower.com

MANUFACTURED UNDER ONE OR MORE OF THE FOLLOWING U.S. PATENTS: 7,063,133 B2; 5,954,492; 5,761,379; 5,943,984; 5,081,696; 5,988,117; 6,142,216; 5,199,385; 5,574,822; 5,372,185; 5,485,879; 5,277,171; (B1)5,341,770; 5,660,165; 5,596,952; 5,682,666; 4,904,428; 5,023,031; 5,000,893; 4,669,448; 4,829,983; 4,808,356; 5,115,767; 5,092,519; 5,052,346; 4,416,222; 4,628,184; 4,861,968; 4,672,919; Re. 34,534. OTHER U.S. AND FOREIGN PATENT APPLICATIONS PENDING. CURRENT CANADIAN PATENTS: 1,272,914; 1,280,043; 1,289,832; 2,045,862; 2,112,515; 2,108,186; 2,107,012; 2,092,105.

PowerStor2™ Series®, Vitrarglas® and Hydrojet® are registered trademarks of Bradford White® Corporation.

Residential Double Wall Indirect Water Heater

PowerStor2™ Series® Energy Saver Models

Meet or exceed ASHRAE 90.1b
(current standard)

Model Number	Capacity		A	B	C	D	E	F	G	Approx. Shipping Weight
	U.S. Gal.	Imp. Gal.	Floor to Heater Top in.	Jacket Dia. in.	Floor to T&P Conn. in.	Floor to Water Conn. in.	Floor to Boiler Return in.	Floor to Boiler Supply in.	Floor to Thermostat in.	
DW-2-40-L	38	32	41	22	34%	41%	5%	27%	11%	170
DW-2-50-L	48	40	46%	22	40%	47%	5%	27%	11%	180
DW-2-65-L	64	54	59	22	53%	60	5%	27%	11%	196
DW-2-80-L	75	63	59	24	52%	59%	5%	27%	11%	224

Model Number	Capacity		A	B	C	D	E	F	G	Approx. Shipping Weight
	Liters		mm.	mm.	mm.	mm.	mm.	mm.	mm.	
DW-2-40-L	144		1045	559	873	1083	137	699	292	76
DW-2-50-L	182		1175	559	1019	1200	137	699	292	89
DW-2-65-L	242		1505	559	1349	1527	137	699	292	89
DW-2-80-L	284		1505	610	1343	1518	137	699	292	102

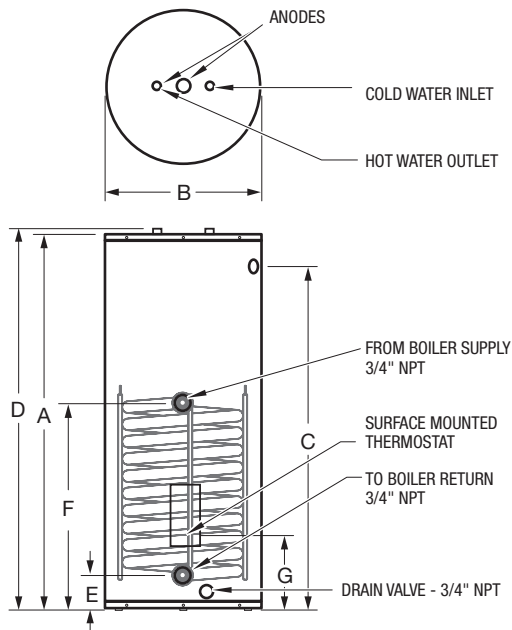

I=B=R Water Heater Ratings					
Model Number	First Hour Rating @ 135°F (Gal.)	Continuous Draw Rating @ 135°F (Gal./Hr.)	Standby Heat Loss Rating (°F/Hr.)	Minimum Heat Req. Rate (BTU/Hr.)	Minimum Heat Source Flow Rate (Gal./Min.)
DW-2-40-L	123	98	1.1	65,000	8.0
DW-2-50-L	133	98	0.9	65,000	8.0
DW-2-65-L	148	98	0.7	65,000	8.0
DW-2-80-L	158	98	0.6	65,000	8.0

NOTES: These certified ratings were obtained with a heat source output rate and flow rate as specified and a 180° F boiler water supply temperature. Other results will be obtained under different conditions.

DOE Water Heater Performance					
Model Number	Maximum First Hour Rating (Gal.) @		Continuous Draw Rating (Gal./Min.) @		Approximate Boiler Output Needed For Ratings (BTU/Hr.)
	140°F	115°F	140°F	115°F	
DW-2-40-L	80	122	0.9	1.6	55,000
DW-2-50-L	87	129	0.9	1.6	55,000
DW-2-65-L	96	138	0.9	1.6	55,000
DW-2-80-L	106	148	0.9	1.6	55,000

NOTES: Based on 200° F boiler water temperature and 50° F potable water inlet temperature.

Heat Exchanger Head Loss					
GPM	2	5	8	10	12
Ft. of Hd. Loss	trace	0.4	2.3	4.6	6.9

Meets NAECA Requirements

General

All units are certified at 300 PSI test pressure (2068 kPa) and 150 PSI working pressure (1034 kPa). All potable water and heat exchanger connections are 3/4" NPT (19mm) on 8" (203mm) centers.

Dimensions and specifications subject to change without notice in accordance with our policy of continuous product improvement.

Suitable for Water (Potable) Heating and Space Heating.

Toxic chemicals, such as those used for boiler treatment, shall NEVER be introduced into the potable water side. The potable side of this unit may NEVER be connected to any existing heating system or component(s) previously used with a non-potable water heating appliance. The heat exchanger side of the unit may be used in space heating applications.



Ambler, PA

For U.S. and Canada field service, contact your professional installer or local Bradford White sales representative.

Sales 800-523-2931 • Fax 215-641-1670 / Technical Support 800-334-3393 • Fax 269-795-1089 • Warranty 800-531-2111 • Fax 269-795-1089

International: Telephone 215-641-9400 • Telefax 215-641-9750 / www.bradfordwhite.com



BRADFORD WHITE-CANADA INC. Sales / Technical Support 866-690-0961 / 905-238-0100 • Fax 905-238-0105 / www.bradfordwhite.com

Built to be the Best™

©2007, Bradford White Corporation. All rights reserved.