

Solar Saver[®] Electric Backup Models



Photo is of
MS80R6SS

The Solar Saver[®] Models feature:

- **Backup Element**—A single backup heating element provides heat only when solar energy does not satisfy demand.
- **Factory Installed Hydrojet[®] Total Performance System**—Cold water inlet sediment reducing device helps prevent sediment build up in tank. Increases first hour delivery of hot water while minimizing temperature build up in tank.
- **Vitraglas[®] Lining**—Bradford White tanks are lined with a exclusively engineered enamel formula that provides superior protection from the highly corrosive effects of hot water. This formula (Vitraglas[®]) is fused to the steel surface by firing at a temperature of over 1600°F.
- **Fully Automatic Controls**—Fast acting surface-mount thermostat for automatic temperature control. Factory installed sensitive manual reset energy cutoff for safety to prevent overheating.
- **Supply and Return Connections**—3/4" NPT female connections are located on the top for both the solar collector supply and return.
- **Alternate Solar Collector Supply and Return Connections**—Located on the front for additional application flexibility (MS80 and MS120 only).
- **2" Non-CFC Foam Insulation**—Covers the sides and top of tank, reducing the amount of heat loss. This results in less energy consumption, improved operation efficiencies and jacket rigidity.
- **Potable Water Connections**—3/4" NPT factory installed true dielectric fittings extend water heater life and eases installation.
- **Sensor Wires for Solar Thermistor Connections**—Twisted wires are provided as a means for connecting thermistors to a solar controller (thermistors and solar controller are not provided).
- **Protective Magnesium Anode Rod**—Provide added protection against corrosion for long trouble-free service.
- **Direct Heat Transfer With Immersed Element**—Transfers heat directly and efficiently to the water. Screw-in style.
- **T&P Relief Valve**—Included.
- **Brass Drain Valve**—Tamper proof design.



6-Year Limited Tank Warranties / 6-Year Limited Warranty on Component Parts.

For more information on warranty, please visit www.bradfordwhite.com

For products installed in USA, Canada and Puerto Rico. Some states do not allow limitations on warranties. See complete copy of the warranty included with the heater.

MANUFACTURED UNDER ONE OR MORE OF THE FOLLOWING U.S. PATENTS: 5,954,492; 5,761,379; 5,943,984; 5,081,696; 5,988,117; 6,142,216; 5,199,385; 5,574,822; 5,372,185; 5,485,879; 5,277,171; (B1)5,341,770; 5,660,165; 5,596,952; 5,682,666; 4,904,428; 5,023,031; 5,000,893; 4,669,448; 4,829,983; 4,808,356; 5,115,767; 5,092,519; 5,052,346; 4,416,222; 4,628,184; 4,861,968; 4,672,919; Re. 34,534; 7,270,087 B2. OTHER U.S. AND FOREIGN PATENT APPLICATIONS PENDING. CURRENT CANADIAN PATENTS: 1,272,914; 1,280,043; 1,289,832; 2,045,862; 2,112,515; 2,108,186; 2,107,012; 2,092,105; 2,409,271. Vitraglas[®] and Hydrojet[®] are registered trademarks of Bradford White[®] Corporation.

Solar Saver® Water Heater System

Electric Backup Models

Meet or exceed ASHRAE 90.1b (current standard)

Model Number	Capacity		Recovery at 90°F Rise*		A Floor to Heater Top	B Jacket Dia.	C Floor to Water Conn.	D Floor to T&P Conn.	E Floor to Alt. Collector Return Conn.	F Floor to Alt. Collector Supply Conn.	Approx. Shipping Weight
	U.S. Gal.	Imp. Gal.	U.S. GPH	Imp. GPH	in.	in.	in.	in.	in.	in.	lbs.
MS65R6SS	65	54	21	18	59	22	60	52½	—	—	168
MS80R6SS†	80	67	21	18	59	24	60	52½	38	7⅞	210
MS120R6SS†	119	99	21	18	62½	28	63½	56	38¼	7⅞	310

Model Number	Capacity		Recovery at 50°C Rise*		A Floor to Heater Top	B Jacket Dia.	C Floor to Water Conn.	D Floor to T&P Conn.	E Floor to Alt. Collector Return Conn.	F Floor to Alt. Collector Supply Conn.	Approx. Shipping Weight
	Liters	Liters/ Hour	mm.	mm.	mm.	mm.	mm.	mm.	mm.	mm.	kg.
MS65R6SS	246	79	1499	559	1524	1334	—	—	—	—	75
MS80R6SS†	303	79	1499	610	1524	1334	965	200	200	95	
MS120R6SS†	450	79	1594	711	1613	1422	972	200	200	141	

* Based on 4500W operation

† Models offer additional solar collector return connections.

If requirements are for storage only, do not use element connections.

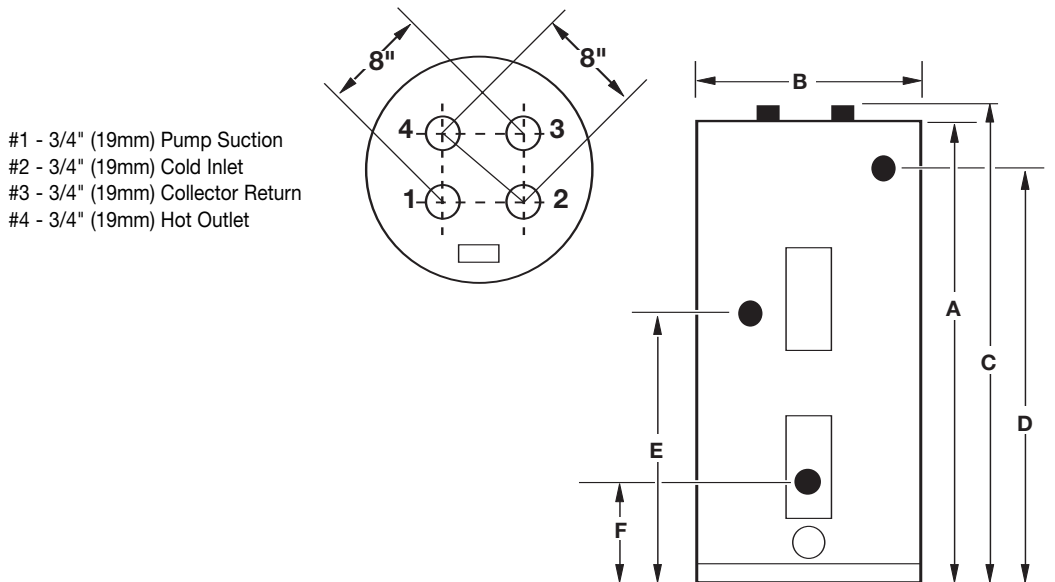

General

All electric water heaters are certified at 300 PSI test pressure (2068 kPa) and 150 PSI working pressure (1034 kPa). All potable water and electrical connections are 3/4" NPT (19mm) on 8" (203mm) centers. All models UL listed.

Dimensions and specifications subject to change without notice in accordance with our policy of continuous product improvement.

Suitable for Water (Potable) Heating and Space Heating.

Toxic chemicals, such as those used for boiler treatment, shall NEVER be introduced into the potable side of this system. The potable side may NEVER be connected to any existing heating system or component(s) previously used with a non-potable water heating appliance.



Ambler, PA

For U.S. and Canada field service, contact your professional installer or local Bradford White sales representative.

Sales 800-523-2931 • Fax 215-641-1670 / Technical Support 800-334-3393 • Fax 269-795-1089 • Warranty 800-531-2111 • Fax 269-795-1089

International: Telephone 215-641-9400 • Telefax 215-641-9750 / www.bradfordwhite.com

BRADFORD WHITE-CANADA INC. Sales / Technical Support 866-690-0961 / 905-238-0100 • Fax 905-238-0105 / www.bradfordwhite.com

Built to be the Best™

©2009, Bradford White Corporation. All rights reserved.