

Commercial Medium Duty-3 Element Energy Saver Electric Water Heater



Photo is of
E32-50S-3

The Medium Duty Electric Models Feature:

- **Fully Automatic Controls**—Fast acting surface-mount thermostat for automatic temperature control. Factory installed sensitive manual reset energy cut-off for safety to prevent overheating. (Maximum thermostat setting is 185°F.)
- **Direct Heat Transfer With Three Immersed Incoloy Elements**—Transfers heat directly and efficiently to the water. Screw-in style element.
- **Factory Installed Hydrojet[®] Total Performance System**—Cold water inlet sediment reduction device helps minimize sediment build up in tank. Increases first hour delivery of hot water while minimizing temperature build up at top of tank.
- **Vitraglas[®] Lining**—Bradford White water heater tanks are protected from the corrosive effects of hot water by an exclusive ceramic porcelain-like coating. The Bradford White high silica Vitraglas[®] lining provides a tough interior surface for our hot water tanks.
- **2" Non-CFC Foam Insulation**—Covers the side and top of tank, reducing the amount of heat loss. This results in less energy consumption, improved operation efficiencies and jacket rigidity.
- **Water Connections**—1¼" NPT factory installed true dielectric fittings extend water heater life and eases installation.
- **Conversion Kits**—Design certified by UL for field conversion. Conversion kits are available to convert any one model to a variety of voltages, kW inputs and wire phase. (kit part numbers on reverse side.)
- **Protective Magnesium Anode Rod**—Provides added protection against corrosion for long trouble-free service.
- **Steel Tank**—Heavy gauge steel automatically formed, rolled and welded.
- **T&P Relief Valve**—Supplied.
- **Brass Drain Valve.**



3 or 5-Year Limited Tank Warranties / 1-Year Limited Warranty on Component Parts.

For more information on warranty, please visit www.bradfordwhite.com

For products installed in USA, Canada and Puerto Rico. Some states do not allow limitations on warranties. See complete copy of the warranty included with the heater.

Commercial Electric Water Heater

Commercial Medium Duty Energy Saver Models

Meet or exceed ASHRAE 90.1b (current standard) C.E.C. Listed

Model Number	Capacity		Recovery 100°F Rise		A Floor to Heater Top	B Jacket Dia.	C Floor to Water Conn.	D Floor to T&P Conn.	E Floor to Control Box	F Control Box to Back of Heater	Approx. Shipping Weight
	U.S. Gal.	Imp. Gal.	U.S.* GPH	Imp.* GPH	in.	in.	in.	in.	in.	in.	lbs.
E32-50S-3	50	42	74	62	46½	22	47½	47⅞	44⅞	24⅝	137
E32-80R-3	80	67	74	62	59	24	60	60⅞	57⅞	26¾	190
E32-120R-3	119	99	74	62	63	28¼	64	64⅞	61⅞	30⅞	312

Model Number	Capacity		Recovery 56°C Rise	A Floor to Heater Top	B Jacket Dia.	C Floor to Water Conn.	D Floor to T&P Conn.	E Floor to Control Box	F Control Box to Back of Heater	Approx. Shipping Weight
	Liters	Liters*	Liters*/Hour	mm.	mm.	mm.	mm.	mm.	mm.	kg.
E32-50S-3	189	280	280	1181	559	1207	1210	1140	625	62
E32-80R-3	303	280	280	1499	610	1524	1527	1457	679	86
E32-120R-3	450	280	280	1600	730	1626	1629	1568	784	142

All models are wired 240V, 3-phase, 18kW. Other voltages, wattages and kW are available and must be specified when ordering.

For 5 year models, change suffix "3" to "5".

*Based on 18kW operation.

NSF Construction available.

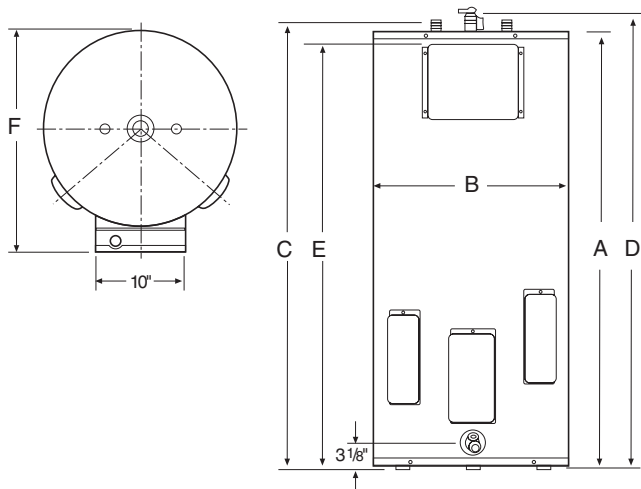

Conversion Kit Table

Required Total Heater kW	Each Element Wattage	Kit Part Numbers		
		208V	240V	480V
6	2000	265-43942-13	265-43942-07	265-43942-01
9	3000	265-43942-14	265-43942-08	265-43942-02
12	4000	265-43942-15	265-43942-09	265-43942-03
13.5	4500	265-43942-16	265-43942-10	265-43942-04
15	5000	265-43942-17	265-43942-11	265-43942-05
18	6000	N/A	265-43942-12	265-43942-06

Full Load Amperes - (Single Phase / Three Phase) and Recovery at °F Rise

Input kW	208V	240V	277V	380V	415V	480V	40°F	100°F	140°F
6	28.8/16.6	25/14.4	21.6	10	8.3	12.5/7.2	62	25	18
9	43.2/25	37.5/21.6	32.4	14	12.5	18.7/10.8	93	37	27
12	57.6/33.3	50/28.9	43.3	19	16.7	25/14.4	124	50	35
13.5	64.9/37.5	56.2/32.5	48.7	21	18.8	28.1/16.2	139	56	40
15	72.1/37.5	62.5/36.1	54.1	23	20.9	31.2/18	155	62	44
18	86.5/50	75/43.4	64	28	25	37.5/21.6	186	74	53

Sample Specification

Water heater shall be a Bradford White model with a rated storage capacity of not less than _____ gallons/liters, a minimum kW input of _____, and a minimum recovery of _____ GPH/LPH at 100°F (56°C) temperature rise. It shall be designed certified either with or without a separate storage tank. The tank shall be lined with Vitraglas® vitreous enamel. The tank should consist of three screw type elements with a combined maximum input of 18 kW. The tank shall have one magnesium anode rod. The units should be design certified by UL/CUL for field conversions with specific kits available from the factory. The heater shall be insulated with not less than 2" (51mm) of Non-CFC foam. This water heater shall be equipped with an ASME rated T&P relief valve. The entire installation shall be made in compliance with state and local codes and ordinances.

General

All models UL and CUL listed.

All potable water connections are 1¼" (25mm) NPT on 8" (203mm) centers.

All electrical connections are 3/4" (19mm) NPT.

All models certified at 300 psi test pressure (2068 kPa) and 150 psi working pressure (1034 kPa).

Dimensions and specifications subject to change without notice in accordance with our policy of continuous product improvement.



For U.S. and Canada field service, contact your professional installer or local Bradford White sales representative.

Sales 800-523-2931 • Fax 215-641-1670 / Technical Support 800-334-3393 • Fax 269-795-1089 • Warranty 800-531-2111 • Fax 269-795-1089

International: Telephone 215-641-9400 • Telefax 215-641-9750 / www.bradfordwhite.com

BRADFORD WHITE-CANADA INC. Sales / Technical Support 866-690-0961 / 905-238-0100 • Fax 905-238-0105 / www.bradfordwhite.com

Built to be the Best™

©2008, Bradford White Corporation. All rights reserved.