

Residential Atmospheric Vent High EF Energy Saver Gas Water Heater



Photo is of
M-4-40T6FBN

FEATURING:



The Atmospheric Vent FVIR Defender Safety System[®] Models Feature:

- **ENERGY STAR[®] Qualified**—These models qualify for the January 1st, 2009 minimum ENERGY STAR[®] EF requirement, as well as most utility rebate programs.
- **Bradford White ICON System[™]**—Intelligent gas control with proven millivolt powered technology and built-in piezo igniter. A standard, off the shelf thermopile converts heat energy from the pilot flame into electrical energy to operate the gas valve and microprocessor. No need for external electricity.
 - **Enhanced Performance**—Proprietary algorithms provide enhanced First Hour Delivery ratings and tighter temperature differentials.
 - **Advanced Temperature Control System**—Microprocessor constantly monitors and controls burner operation to maintain consistent and accurate water temperature levels.
 - **Intelligent Diagnostics**—An exclusive green LED light prompts the installer during start-up and provides ten different diagnostic codes to assist in troubleshooting.
 - **Pilot On Indication**—Flashing green LED provides positive indication that pilot is on.
 - **Separate Immersed Thermowell**—High strength advanced polymer composite thermowell provides isolation between electric temperature sensor and surrounding water. No need to drain the tank when removing gas valve.
- **Advanced ScreenLok[®] Technology Flame Arrestor Design**—Flame arrestor is designed to prevent ignition of flammable vapor outside of the water heater.
- **Resettable Thermal Switch**—Proven and reliable bimetallic switch prevents burner and pilot operation in case of ongoing flammable vapor burn inside of the combustion chamber or restricted air flow.
- **Maintenance Free**—No regular cleaning of air inlet openings or flame arrestor is required under normal conditions.
- **Sight Window**—Offers a view into the combustion chamber to observe the operation of the pilot and burner.
- **Factory Installed Hydrojet[®] Total Performance System**—Cold water inlet sediment reducing device helps prevent sediment build up in tank. Increases first hour delivery of hot water while minimizing temperature build up in tank.
- **Vitraglas[®] Lining**—Bradford White tanks are lined with a exclusively engineered enamel formula that provides superior protection from the highly corrosive effects of hot water. This formula (Vitraglas[®]) is fused to the steel surface by firing at a temperature of over 1600°F.
- **2" Non-CFC Foam Insulation**—Covers the side and top, reducing the amount of heat loss. This results in less energy consumption, improved operation efficiencies and jacket rigidity.
- **Pedestal Base.**
- **Water Connections**—3/4" NPT factory installed true dielectric fittings.
- **Factory Installed Heat Traps.**
- **Protective Magnesium Anode Rod.**
- **3x4 "Snap Lock" Draft Diverter**—Allows either 3" or 4" vent connections with inputs of 40,000 BTU/Hr or less.
- **T&P Relief Valve**—Included.
- **Brass Drain Valve**—Tamper proof design.

6 or 10-Year Limited Tank Warranties / 6-Year Limited Warranty on Component Parts.

For more information on warranty, please visit www.bradfordwhite.com

For products installed in USA, Canada and Puerto Rico. Some states do not allow limitations on warranties. See complete copy of the warranty included with the heater.



Residential Atmospheric Vent Gas Water Heater

High EF Energy Saver Models

NATURAL GAS AND LIQUID PROPANE GAS

Meet or exceed ASHRAE 90.1b (current standard) C.E.C. Listed
80% Recovery Efficiency

Model Number	Capacity		Recovery* 90°F Rise				A Floor to Flue Conn.	B Jacket Dia.	C Vent Size	D Floor to T&P Conn.	E Floor to Gas Conn.	F Floor to Water Conn.	Approx. Shipping Weight		
	U.S. Gal.	Imp. Gal.	Nat. BTU/Hr. Input	LP BTU/Hr. Input	Nat. U.S. GPH	Nat. Imp. GPH								LP U.S. GPH	LP Imp. GPH
M-4-30T6FBN●	30	25	32,000	31,000	34	28	33	27	59 ¹ / ₈	18	3x4	49 ³ / ₄ / 56 ³ / ₈	13	57 ¹ / ₂	114
M-4-40T6FBN●	40	33	40,000	36,000	43	36	38	32	59 ³ / ₈	20	3x4	50 / 56 ³ / ₈	13	57 ³ / ₄	128
M-4-40S6FBN●	40	33	40,000	38,000	43	36	40	33	50	22	3x4	41 / 47 ¹ / ₄	13	48 ¹ / ₂	133
M-4-50S6FBN●	50	42	40,000	36,000	43	36	38	32	59 ³ / ₈	22	3x4	50 / 57	13	58	151
M-4-60T6FBN	60	50	40,000	38,000	43	36	40	33	60 ³ / ₄	24	3x4	50 ¹ / ₂	13	58 ¹ / ₄	192

Model Number	Capacity		Recovery* 50°C Rise				A Floor to Flue Conn.	B Jacket Dia.	C Vent Size	D Floor to T&P Conn.	E Floor to Gas Conn.	F Floor to Water Conn.	Approx. Shipping Weight
	Liters		Nat. kW Input	LP kW Input	Nat. Liters/Hour	LP Liters/Hour							
M-4-30T6FBN●	114		9.4	9.1	129	125	1502	457	76x102	1264 / 1432	330	1460	52
M-4-40T6FBN●	151		11.7	10.5	163	144	1508	508	76x102	1270 / 1438	330	1467	58
M-4-40S6FBN●	151		11.7	11.1	163	151	1270	559	76x102	1041 / 1200	330	1232	60
M-4-50S6FBN●	189		11.7	10.5	163	144	1514	559	76x102	1270 / 1448	330	1473	68
M-4-60T6FBN	227		11.7	11.1	163	151	1543	609	76x102	1282	330	1480	87

Propane models feature a Titanium Stainless Steel propane burner. For Propane (LP) models change suffix "BN" to "SX".

For 10 year models, change suffix from "6" to "10".

*Based on manufacturers rated recovery efficiency.

- Models feature optional top T&P location and must be specified when ordering (M-4-60T does not have top T&P option).

M-4-30T and M-4-60T do not qualify for ENERGY STAR®.

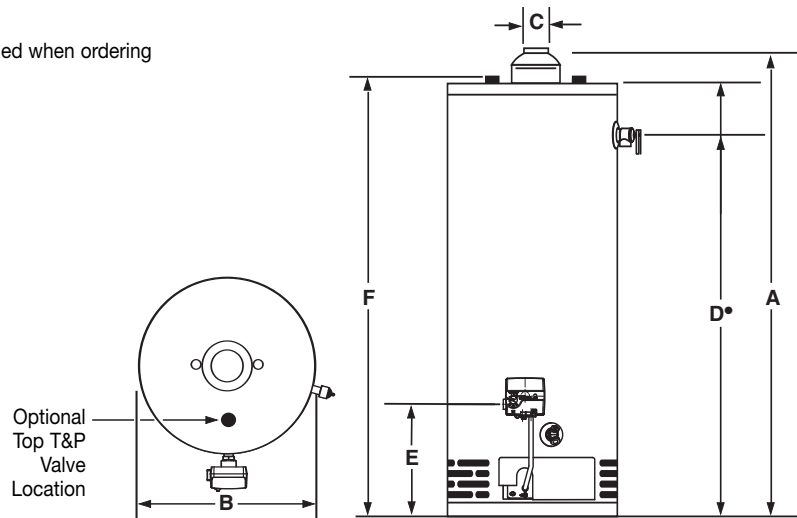

"D" dimension listed as side/top.

Meets NAECA Requirements

General

All gas water heaters are certified at 300 PSI test pressure (2068 kPa) and 150 PSI working pressure (1034 kPa). All potable water connections are 3/4" NPT (19mm) on 8" (203mm) centers. All models design certified by CSA International (formerly AGA/CGA), ANSI Z-21.10.1 and peak performance rated.

Dimensions and specifications subject to change without notice in accordance with our policy of continuous product improvement.

Suitable for Water (Potable) Heating and Space Heating.

See Gas Appliance Manufacturers Association (GAMA) for current Energy Factor ratings.

Toxic chemicals, such as those used for boiler treatment, shall NEVER be introduced into the potable side of this system. The potable side may NEVER be connected to any existing heating system or component(s) previously used with a non-potable water heating appliance.



Ambler, PA

For U.S. and Canada field service, contact your professional installer or local Bradford White sales representative.

Sales 800-523-2931 • Fax 215-641-1670 / Technical Support 800-334-3393 • Fax 269-795-1089 • Warranty 800-531-2111 • Fax 269-795-1089

International: Telephone 215-641-9400 • Telefax 215-641-9750 / www.bradfordwhite.com



BRADFORD WHITE-CANADA INC. Sales / Technical Support 866-690-0961 / 905-238-0100 • Fax 905-238-0105 / www.bradfordwhite.com

Built to be the Best™

©2009, Bradford White Corporation. All rights reserved.